

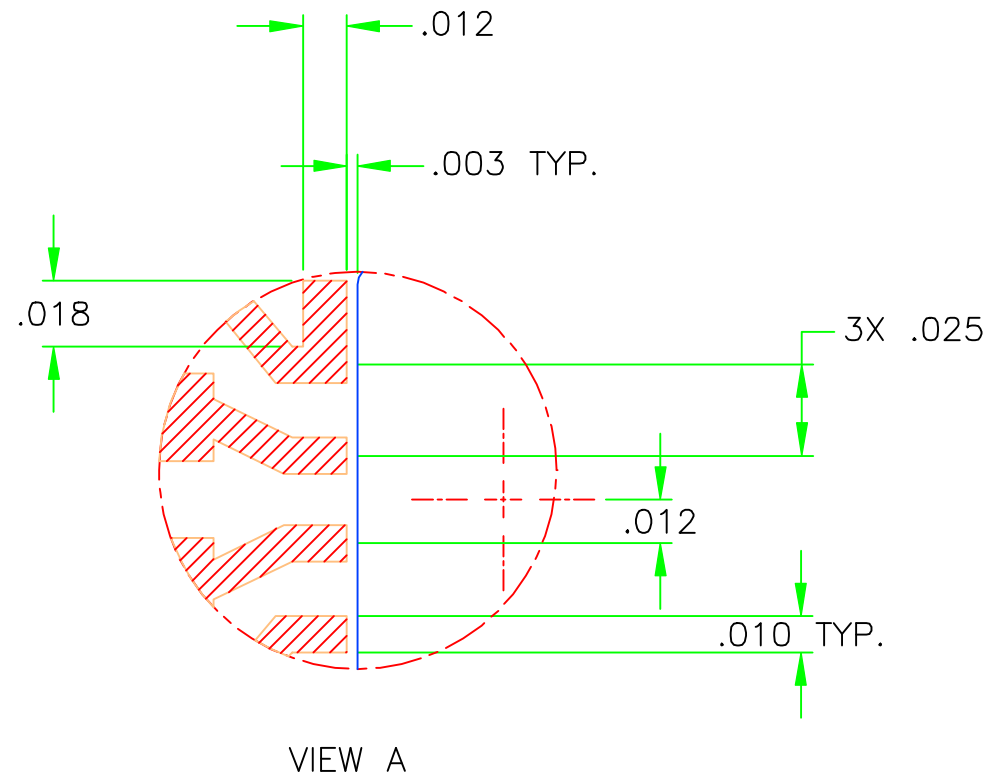

PROPRIETARY  
 THE INFORMATION CONTAINED IN OR DISCLOSED BY THIS DOCUMENT IS CONSIDERED PROPRIETARY BY STRATEDGE CORPORATION. THE ITEMS AND INFORMATION CONTAINED OR DISCLOSED HEREIN SHALL NOT BE USED, COPIED OR REPRODUCED IN WHOLE OR IN PART, NOR SHALL THE CONTENTS BE REVEALED IN ANY MANNER TO ANY PERSON UNLESS WRITTEN PERMISSION IS FIRST OBTAINED FROM STRATEDGE CORPORATION.

NOTES, UNLESS OTHERWISE SPECIFIED:

1. BASE MATERIAL IS COPPER COMPOSITE METAL.
2. CERAMIC SHALL BE 96% Al<sub>2</sub>O<sub>3</sub>.
3. LEAD, BASE, AND CERAMIC GOLD PLATING THICKNESS SHALL BE 50 MICROINCHES MINIMUM, MEASURED ON MAJOR FLATS.
4. LEAD, BASE, AND CERAMIC NICKEL UNDERPLATE SHALL BE 100 TO 350 MICROINCHES, MEASURED ON MAJOR FLATS.
5. PACKAGE WILL BE SUPPLIED ON A LEAD FRAME. LEAD FRAME WILL BE SUITABLE FOR MINIMUM LEAD LENGTH OF .10" AFTER TRIM.
6. LID: REFERENCE STRATEDGE PART NUMBER TBD.

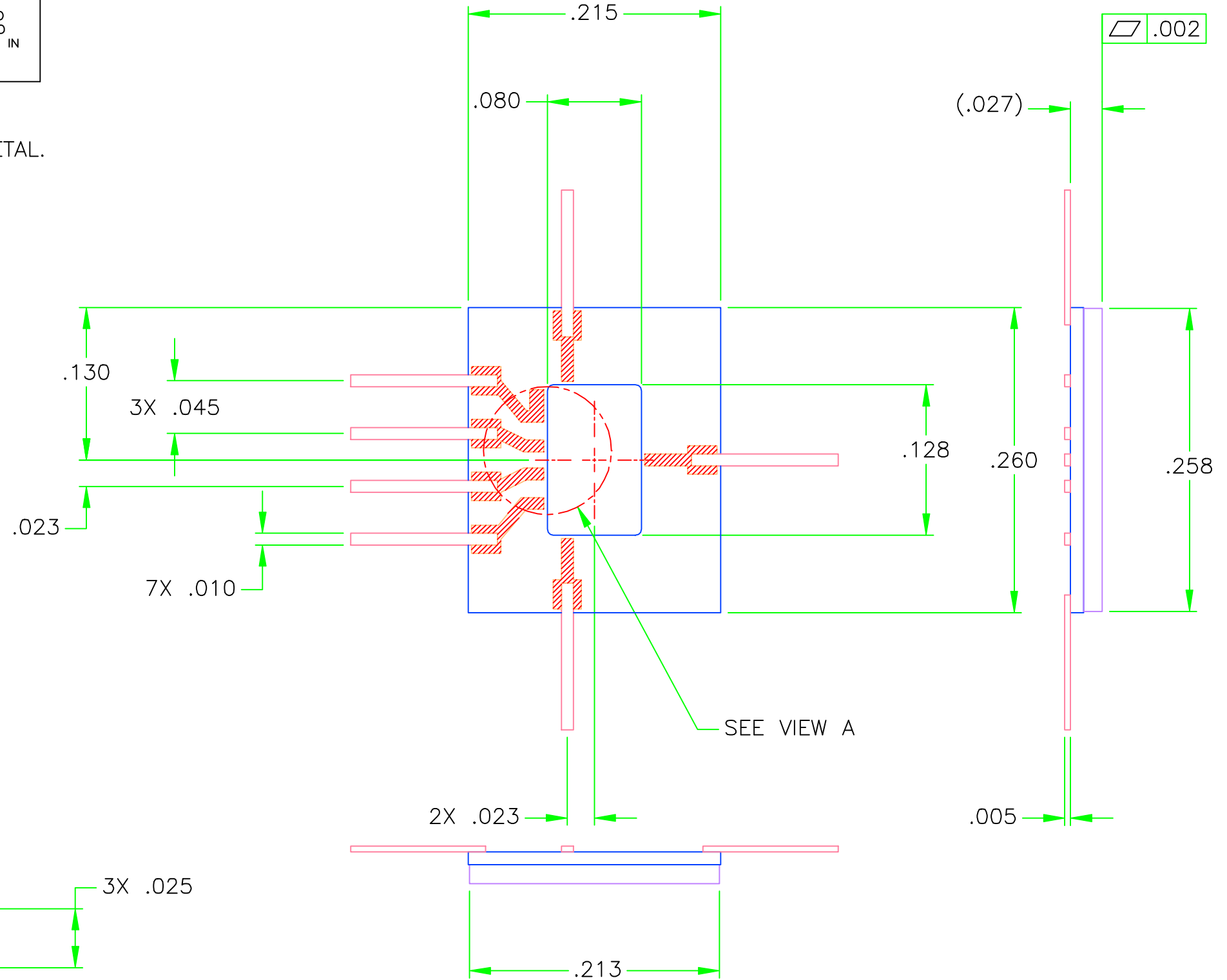

UNLESS OTHERWISE SPECIFIED ● DIMENSIONS ARE IN INCHES [MM] ● TOLERANCES: ANGLES +/- 1 DEG 4 PL DECIMALS ±.0005 [.013] 3 PL DECIMALS ±.005 [.13] 2 PL DECIMALS ±.01 [.25]	DRAFTER	DATE	 4393 Viewridge Avenue San Diego, CA 92123
	PROJECT ENGINEER	DATE	
	CHECKER	DATE	
	MARKETING	DATE	
7 LEAD LCC PACKAGE OUTLINE/CATALOG DRAWING			
SIZE	CAGE CODE	DRAWING NO	REV
B	OHZT6	C580411	A
SCALE	NONE	C580411A	SHEET 1 OF 1