

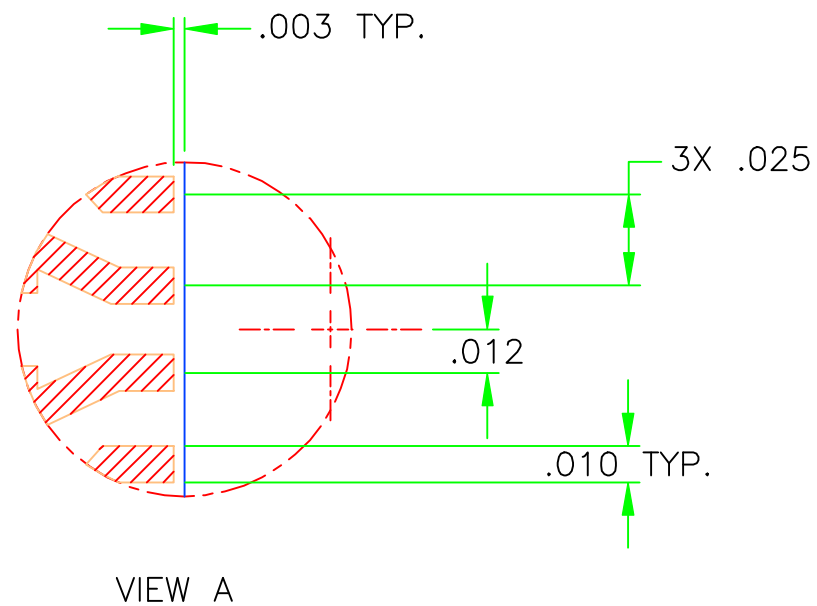

PROPRIETARY  
 THE INFORMATION CONTAINED IN OR DISCLOSED BY THIS DOCUMENT IS CONSIDERED PROPRIETARY BY STRATEDGE CORPORATION. THE ITEMS AND INFORMATION CONTAINED OR DISCLOSED HEREIN SHALL NOT BE USED, COPIED OR REPRODUCED IN WHOLE OR IN PART, NOR SHALL THE CONTENTS BE REVEALED IN ANY MANNER TO ANY PERSON UNLESS WRITTEN PERMISSION IS FIRST OBTAINED FROM STRATEDGE CORPORATION.

NOTES, UNLESS OTHERWISE SPECIFIED:

1. BASE MATERIAL IS COPPER COMPOSITE METAL.
2. CERAMIC SHALL BE 96%  $Al_2O_3$ .
3. LEAD, BASE, AND CERAMIC GOLD PLATING THICKNESS SHALL BE 50 MICROINCHES MINIMUM, MEASURED ON MAJOR FLATS.
4. LEAD, BASE, AND CERAMIC NICKEL UNDERPLATE SHALL BE 100 TO 350 MICROINCHES, MEASURED ON MAJOR FLATS.
5. PACKAGE WILL BE SUPPLIED ON A LEAD FRAME. LEAD FRAME WILL BE SUITABLE FOR MINIMUM LEAD LENGTH OF .10" AFTER TRIM.
6. LID: REFERENCE STRATEDGE PART NUMBER TBD.

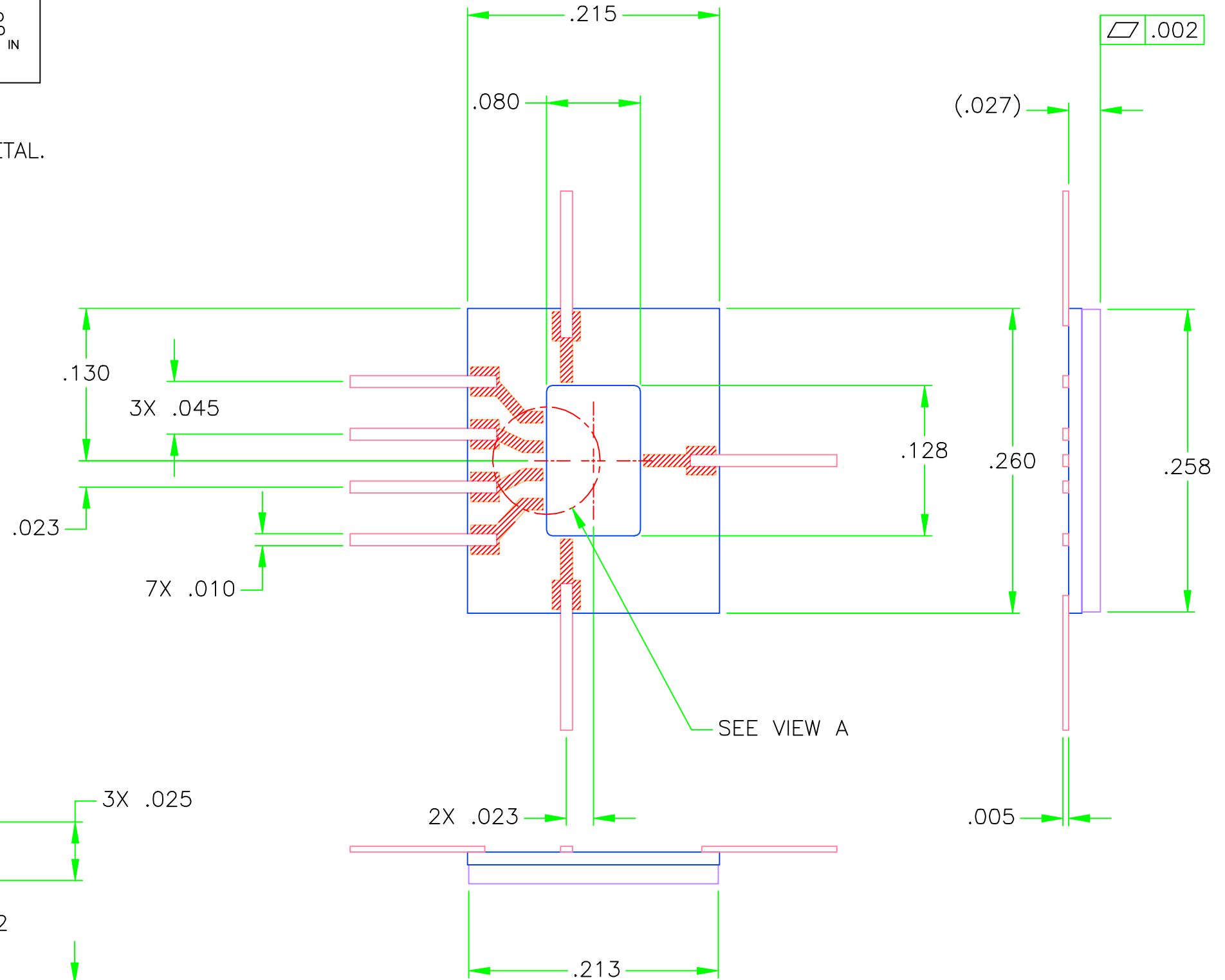

UNLESS OTHERWISE SPECIFIED ● DIMENSIONS ARE IN INCHES [MM] ● TOLERANCES: ANGLES +/- 1 DEG 4 PL DECIMALS ±.0005 [.013] 3 PL DECIMALS ±.005 [.13] 2 PL DECIMALS ±.01 [.25]	DRAFTER	DATE	 4393 Viewridge Avenue San Diego, CA 92123	
	PROJECT ENGINEER	DATE		
	CHECKER	DATE	OUTLINE / CATALOG DRAWING FOR 7 LEAD LCC PACKAGE	
	MARKETING	DATE		
	SIZE B	CAGE CODE OHZT6	DRAWING NO C580401	REV -
	SCALE NONE	C580401_1	SHEET 1 OF 1	